

REVISIONS				
REV.	DESCRIPTION	DATE	DRAWN	APPROVED
A	FIRST ISSUE	15/02/17	BAF	---

NOTES.

SUITABILITY - THIS SITE PREPARATION IS APPLICABLE FOR AQUAMATE 3-RING (2210mm) AND 4-RING (2895mm) TANKS ONLY.

WARRANTY - AQUAMATE WARRANTY IS SUBJECT TO SITE PREPARATION AS PER THESE INSTRUCTIONS

NOTIFICATION - ONCE THE SITE PREP IS COMPLETE, CONTACT AQUAMATE AND YOU WILL BE PROVIDED WITH AN INSTALLATION DATE

INSTRUCTIONS

1. THE TANK PAD DIAMETER MUST BE AT LEAST 2m LARGER THAN THE TANK FOR INSTALLATION
2. REMOVE ALL LOAM, VEGETATION AND SHARP OBJECTS FROM TANK PAD LOCATION
3. WHEREVER POSSIBLE, THE TANK SHOULD BE EXCAVATED INTO NATURAL GROUND
4. WHEN EXCAVATING A SITE, ADEQUATE DRAINAGE MUST BE INSTALLED TO ALLOW WATER TO BE DIVERTED AROUND THE TANK
5. WHEN USING FILL TO LEVEL A SITE, ADEQUATE RETAINING MUST BE INSTALLED TO MAINTAIN PAD INTEGRITY
6. TANK PAD MATERIAL MUST BE CRUSHED STONE OR SIMILAR, WITH PARTICLE SIZE 6mm OR LESS. TANK PAD BASE TO BE 75mm THICK AND LEVEL WITHIN ±10mm
7. ONCE COMPLETE, ENSURE ANY DAMAGE BY VEHICLES OR LIVESTOCK IS ADEQUATELY REPAIRED
8. ON THE DAY OF INSTALLATION, THE CUSTOMER IS REQUIRED TO HAVE AVAILABLE:
 - A) ENOUGH WATER TO FILL 10% OF THE TANK VOLUME WHILE THE INSTALLER IS ON SITE
 - B) SOMEONE TO ADVISE WHERE NOZZLES ARE TO BE INSTALLED
 - C) PAYMENT OF ANY BALANCE DUE PRIOR TO INSTALLATION
9. ONCE THE TANK INSTALLATION IS COMPLETE, PLACE A LAYER OF FREE DRAINING AGGREGATE AROUND THE PERIMETER OF THE TANK TO REDUCE BASE EROSION

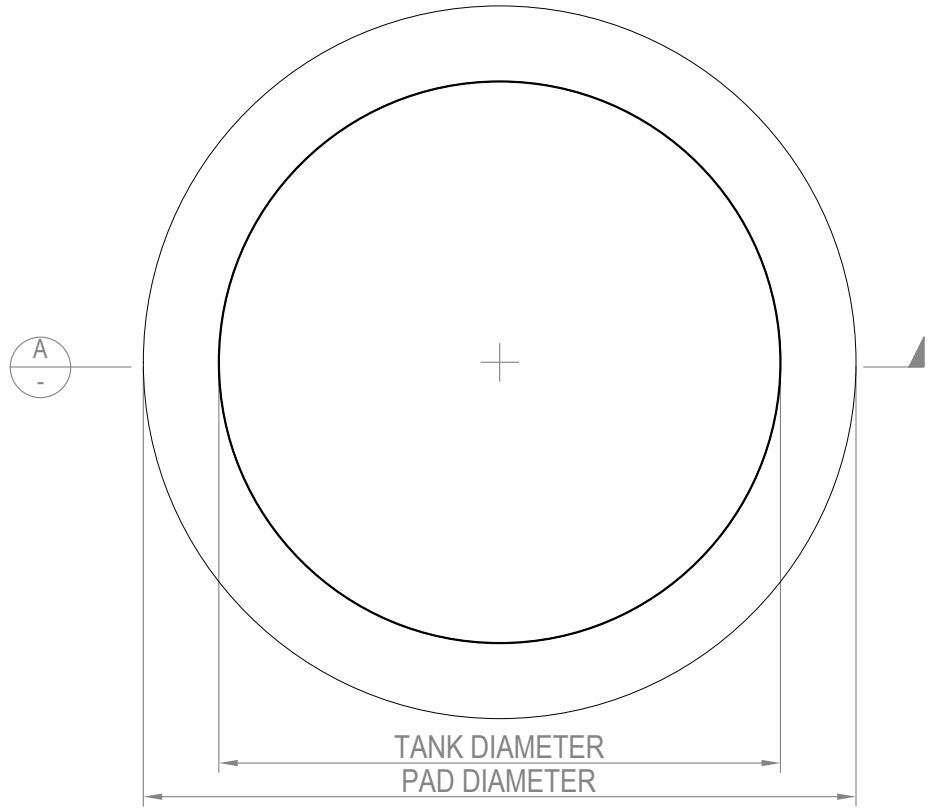

TANK PAD PLAN

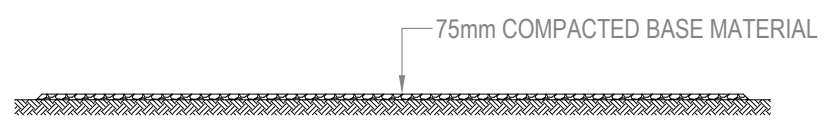

SECTION A

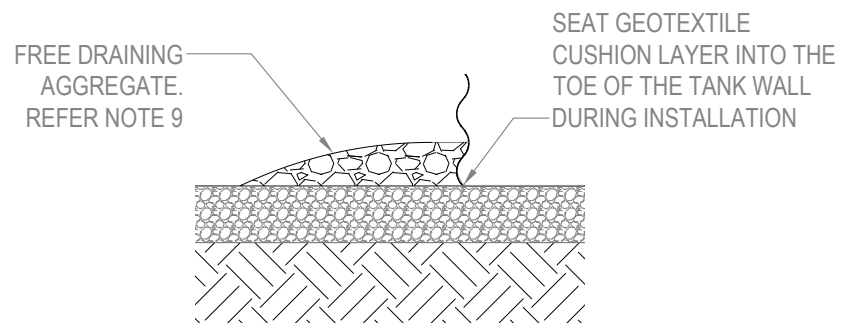

TANK WALL DETAIL

REFERENCE QUANTITIES													
TANK MODEL	G052	G076	G103	G134	G170	G210	G254	G302	G355	G411	G472	G537	G607
DIAMETER	3.7m	4.5m	5.2m	5.9m	6.7m	7.4m	8.2m	8.9m	9.7m	10.4m	11.2m	11.9m	12.6m
PAD DIAMETER	5.7m	6.5m	7.2m	7.9m	8.7m	9.4m	10.2m	10.9m	11.7m	12.4m	13.2m	13.9m	14.6m

AQUAMATE
 16 DRURY TERRACE
 CLOVELLY PARK SA 5042
 P. +61 (0)8 8277 5777
 aquamate.com.au
 info@aquamate.com.au

INIT.	DATE
BAF	15/02/17
DRAWN BY	
CHECKED	
APPROVED	
ISSUED	

DESCRIPTION			
SITE PREPARATION - GEOTEXTILE BASE AQUAMATE MAXI TANK RANGE INSTALLATION			
SCALE	SHEET	DWG No.	SHEET SIZE
N.T.S	1 of 1	Z-00-1000-00001	A4 ISO